

***TB 9-6625-2151-35**

DEPARTMENT OF THE ARMY TECHNICAL BULLETIN

CALIBRATION PROCEDURE FOR TRANSMISSION IMPAIRMENT TEST SET AN/USM-485 AND HEWLETT-PACKARD, MODEL 4935A WITH OPTIONS 001, 002, AND 003

Headquarters, Department of the Army, Washington, DC
9 July 2003

Approved for public release; distribution is unlimited

REPORTING OF ERRORS AND RECOMMENDING IMPROVEMENTS

You can improve this manual. If you find any mistakes or if you know of a way to improve these procedures, please let us know. Mail your letter or DA Form 2028 (Recommended Changes to Publications and Blank Forms) directly to Commander, U.S. Army Aviation and Missile Command, ATTN: AMSAM-MMC-MA-NP, Redstone Arsenal, AL 35898-5000. A reply will be furnished to you. You may also provide DA Form 2028 information to AMCOM via e-mail, fax, or the World Wide Web. Our FAX number is: DSN 788-6546 or Commercial 256-842-6546. Our e-mail address is: 2028@redstone.army.mil. Instructions for sending an electronic 2028 may be found at the back of this manual. For the World Wide Web, use: <https://amcom2028.redstone.army.mil>.

SECTION		Paragraph	Page
I.	IDENTIFICATION AND DESCRIPTION		
	Test instrument identification	1	2
	Forms, records, and reports	2	2
	Calibration description	3	2
II.	EQUIPMENT REQUIREMENTS		
	Equipment required	4	3
	Accessories required	5	3
III.	CALIBRATION PROCESS		
	Preliminary instructions	6	4
	Equipment setup	7	5
	Receiver	8	5
	Transmitter flatness	9	8
	Filters	10	9
	Hold circuit	11	11
	Distortion	12	13
	Peak-to-average ratio (options 002 and 003 only) ...	13	13
	Power supply	14	14
	Final procedure	15	15

*This bulletin superseded TB 9-6625-2151-35 dated 6 January 1993.

**SECTION I
IDENTIFICATION AND DESCRIPTION**

1. Test Instrument Identification. This bulletin provides instructions for the calibration of Transmission Impairment Test Set AN/USM-485 and Hewlett-Packard, Model 4935A with Options 001, 002, and 003. The manufacturer’s manual was used as the prime data source in compiling these instructions. The equipment being calibrated will be referred to as the TI (test instrument) throughout this bulletin.

a. Model Variations. Option 001 adds rechargeable battery pack. Option 002 adds peak/average ratio measurement. Option 003 adds both 001 and 002.

b. Time and Technique. The time required for this calibration is approximately 2 hours, using the dc and low frequency technique.

2. Forms, Records, and Reports

a. Forms, records, and reports required for calibration personnel at all levels are prescribed by TB 750-25.

b. Adjustments to be reported are designated (R) at the end of the sentence in which they appear. When adjustments are in tables, the (R) follows the designated adjustment. Report only those adjustments made and designated with (R).

3. Calibration Description. TI parameters and performance specifications which pertain to this calibration are listed table 1.

Table 1. Calibration Description

Test instrument parameters	Performance specifications ¹
Receiver: Frequency ² Level (input)	Range: 20 Hz to 110 kHz Accuracy: 20 to 9,999 Hz ±0.5 Hz 10 kHz to 110 kHz ±5.0 Hz Range: -40 dBm to +13 dBm Accuracy: ±dBm Frequency: 20 to 50 Hz 1.0 50 to 200 Hz 0.5 0.2 to 15 kHz 0.2 15 to 85 kHz 0.5 85 to 110 kHz N/A (-20 to +13 dBm ±0.1 dBm at 1004 Hz)

See footnotes at end of table.

Table 1. Calibration Description - Continued

Test instrument parameters	Performance specifications ¹
Transmitter: Frequency	Range: 20 Hz to 110 kHz Accuracy: 20 to 99,999 Hz005% 100 to 110 kHz012%
Level (output)	Range: -40 dBm to +10 dBm Flatness: ±dB Frequency: 20 to 200 Hz 1.0 0.2 to 15 kHz 0.2 15 to 85 kHz..... 0.5 85 to 110 kHz..... N/A
Distortion	≤ -50 dB at 1004 Hz and 0 dBm
Filters:	Range: 0 to 100 dBm Accuracy: As listed in table 7
Hold circuit	Range: 24 mA Accuracy: 0.5 mA
Peak-to-average ratio	Range: 0 to 120 P/AR units Accuracy: ±2 P/AR units from 30 to 110 P/AR units Filter response: -30 dBm at 300 Hz 0 dBm at 1000 Hz -10 dBm at 2300 Hz

¹Performance specifications do not apply to TI supplemental characteristics.

²Frequency accuracy checked to ±1 Hz at 200 to 9999 Hz and ±10 Hz above 9999 Hz because of TI resolution.

**SECTION II
EQUIPMENT REQUIREMENTS**

4. Equipment Required. Table 2 identifies the specific equipment to be used in this calibration procedure. This equipment is issued with Secondary Transfer Calibration Standards Set AN/GSM-286. Alternate items may be used by the calibrating activity. The items selected must be verified to perform satisfactorily prior to use and must bear evidence of current calibration. The equipment must meet or exceed the minimum use specifications listed in table 2. The accuracies listed in table 2 provide a four-to-one ratio between the standard and TI.

5. Accessories Required. The accessories required for this calibration are common usage accessories issued as indicated in paragraph 4 above and are not listed in this calibration procedure. The following peculiar accessories are also required for this calibration: BNC to phone plug (WECO 310), Pomona Electronics Model 2798 or equivalent, 2 required and 600Ω feedthrough termination.

TB 9-6625-2151-35

Table 2. Minimum Specifications of Equipment Required

Common name	Minimum use specifications	Manufacturer and model (part number)
AUDIO ANALYZER	Frequency measurement: 85 kHz Accuracy: $\pm 0.001\%$ Capability to measure distortion ≤ -50 dB at 1004 Hz	Boonton, Model 1121 (1121)
CALIBRATOR	Dc voltage: Range: -6.9 to 50 V Accuracy: $\pm 0.1\%$ Ac voltage: Range: -40.05 to 11.95 dBm Frequency: 20 Hz to 85 kHz Accuracy: ± 0.05 dB	John Fluke, Model 5720A (p/o MIS-35947)
MULTIMETER	Range: 6.9 mV to 2.748 V ac, 20 Hz to 85 kHz Accuracy: $\pm 0.57\%$ Range: -0.3 to +0.3 V dc Range: 23.5 to 26 mA dc Accuracy: $\pm 0.52\%$	Hewlett-Packard, Model 3458A (3458A)
OSCILLOSCOPE	Range: 10 V p-p Accuracy: $\pm 3.0\%$	Tektronix, Model 2465BOPT46 (2465BOPT46)
RESISTANCE STANDARD	Range: 400 Ω Accuracy: $\pm 0.1\%$	Biddle-Gray, Model 71-631 (7910328)

**SECTION III
CALIBRATION PROCESS**

6. Preliminary Instructions

a. The instructions outlined in paragraphs **6** and **7** are preparatory to the calibration process. Personnel should become familiar with the entire bulletin before beginning the calibration.

b. Items of equipment used in this procedure are referenced within the text by common name as listed in table 2.

c. Unless otherwise specified, verify the result of each test and, whenever the test requirement is not met, take corrective action before continuing with the calibration. Adjustments required to calibrate the TI are included in the procedure. Additional maintenance information is contained in TM 11-6625-3186-24 and the manufacturer's manual for this TI.

d. When indications specified in paragraphs **8** through **13** are not within tolerance, perform power supply check prior to making adjustments. If adjustments are made, repeat paragraphs **8** through **13**. Do not perform power supply check if all other parameters are within tolerance.

e. Unless otherwise specified all controls and control settings refer to the TI.

7. Equipment Setup

WARNING

HIGH VOLTAGE is used or exposed during the performance of this calibration. DEATH ON CONTACT may result if personnel fail to observe safety precautions. REDUCE OUTPUT(S) to minimum after each step with the performance check where applicable.

- a.** Remove protective cover (upper) from TI only when necessary to make adjustments. Replace cover after completing the adjustments.
- b.** Verify TI rear line module is set for 120 V and the correct fuse is installed.
- c.** Connect TI to a 115 V ac power source.
- d.** Press **POWER ON/STBY** pushbutton to **ON** and allow 5 minutes for warmup and stabilization.

NOTE

Use BNC to phone plug (WECO 310) and adapters as required for TI left **TRMT/RCV 310** and right **RCV/TRMT 310** connections.

8. Receiver

a. Performance Check

- (1) Connect calibrator **OUTPUT HI** and **LO** to TI right **RCV/TRMT 310**.
- (2) Position controls as listed in (a) through (e) below:
 - (a) Press **DISPLAY** key to select **RCV**.
 - (b) Press **NOR** pushbutton.
 - (c) Press **SET UP RCV 600 W** pushbutton.
 - (d) Press **SET UP RCV BRG** pushbutton (in).
 - (e) Press **MEASUREMENT MEAS** key to select **LEVEL FREQUENCY**.

NOTE

The 0.05 dB offset in (3) and (5) below checks round-off error.

(3) Set calibrator for a 11.95 dBm, 20 Hz output. If TI left display does not indicate between 11.0 and 12.9 dBm, perform **b** below. TI right display will indicate between 19 and 21 Hz.

(4) Repeat technique of (3) above at calibrator frequency settings listed in table 3. If TI indications are not within limits specified for +12 dBm, perform **b** below.

Table 3. Receiver Accuracy

Calibrator frequency settings	Test instrument		
	Left display indications for +12 dBm (dBm)	Left display indications for -40 dBm (dBm)	Right display indications
50 Hz	11.5 to 12.4	-40.5 to -39.6	49 to 51 Hz
200 Hz	11.8 to 12.1	-40.2 to -39.9	199 to 201 Hz
500 Hz	11.8 to 12.1	-40.2 to -39.9	499 to 501 Hz
1.0 kHz	11.9 to 12.0	-40.2 to -39.9	999 to 1001 Hz
15 kHz	11.8 to 12.1	-40.2 to -39.9	14.99 to 15.01 kHz
50 kHz	11.5 to 12.4	-40.5 to -39.6	49.99 to 50.1 kHz
85 kHz	11.5 to 12.4	---	84.99 to 85.01 kHz

(5) Set calibrator for a -40.05 dBm, 20 Hz output. If TI left display does not indicate between -41.0 and -39.1 dBm, perform **b** below. TI right display will indicate between 19 and 21 Hz.

(6) Repeat technique of (5) above at calibrator frequency settings listed in table 3. If TI indications are not within limits specified for -40 dBm, perform **b** below.

b. Adjustments

- (1) Press calibrator **RESET** key and disconnect from TI.
- (2) Connect left **TRMT/RCV 310** to right **RCV/TRMT 310** using a T-type connector.
- (3) Connect multimeter **Input HI** and **LO** to T-type connector.
- (4) Press **IMPULSE NOISE DISPLAY F2 1004** key. Right display will indicate 1004 Hz.
- (5) Adjust **OUTPUT LEVEL** control until multimeter indicates about 1.0 V ac. Record exact value.
- (6) Connect multimeter **Input HI** to TP13 (fig. 1) and **LO** to ground. Adjust R77 (fig. 1) until multimeter indicates value recorded in (5) above (R).
- (7) Disconnect left **TRMT/RCV 310** from right **RCV/TRMT 310**.
- (8) Press **MEASUREMENT MEAS** key to select **NOISE** and **DISPLAY** key to select **TRMT**. Connect jumpers from TP10 to TP21 and from TP22 to TP23 (fig. 1).
- (9) Connect multimeter **Input HI** to TP24 (fig. 1). If multimeter does not indicate 0 V dc ± 0.3 mV dc, adjust R33 OFFSET (fig. 1) for 0 V dc. Disconnect jumpers and multimeter (R).
- (10) Set calibrator for a .77 V, 1.004 kHz output. Do not connect to TI at this time.
- (11) Press **DISPLAY** key to select **RCV** and **MEASUREMENT MEAS** key to select **LEVEL FREQUENCY**.
- (12) Press **NOR** and **SET UP RCV 600 W** pushbuttons.

(13) Release **SET UP RCV BRG**, **RCV HOLD**, **TRMT DIAL**, and **TRMT HOLD** pushbuttons (out).

(14) Connect calibrator (preset in (10) above) **OUTPUT HI** and **LO** to TI right **RCV/TRMT 310**. Adjust R23 AVE DET (fig. 1) for > 0.0 dBm indication on TI left display, then reduce until indication just changes to -0.1 dBm (R).

(15) Set calibrator amplitude to .7795 V. TI left display will indicate +0.1 dBm, if not, repeat (14) above at .77 V.

(16) Press **MEASUREMENT MEAS** key to select **NOISE**.

(17) Press **FILTER FILTER** key to select **15 kHz FLAT**.

(18) Set calibrator amplitude to .727 V.

(19) Adjust R65 QRMS DET (fig. 1) until TI left display indicates 90 dBm then reduce level until indication just changes to a stable 89 dBm (R).

(20) Set calibrator amplitude to .826 V. TI left display will indicate 91 dBm, if not repeat (18) and (19) above.

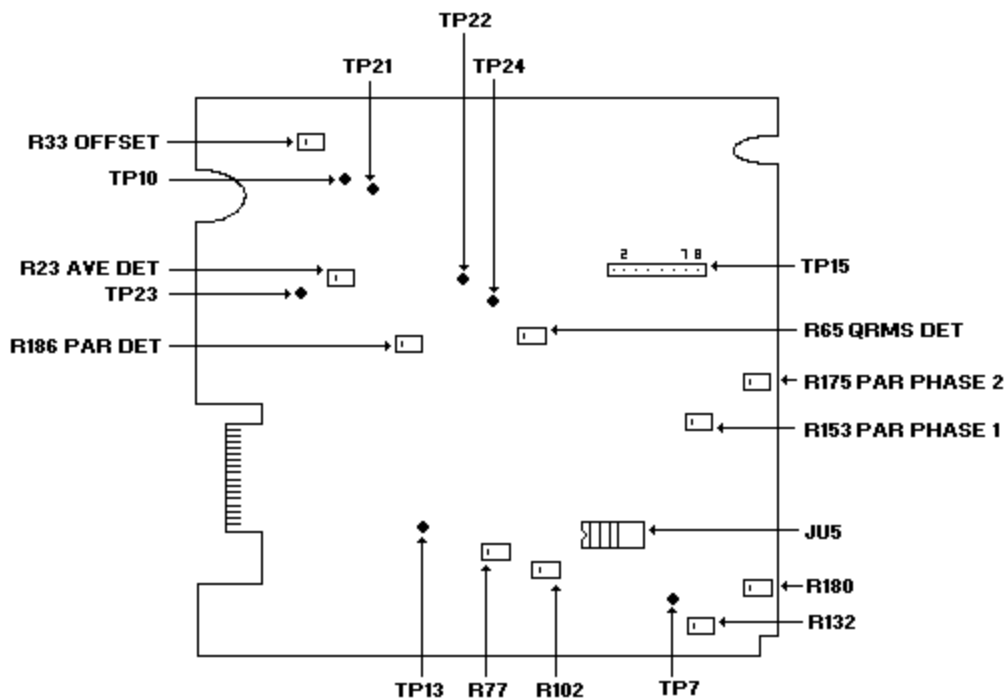

Figure 1. Receiver board A3 (A13) - adjustment locations.

TB 9-6625-2151-35

9. Transmitter Flatness

a. Performance Check

- (1) Connect TI left **TRMT/RCV 310** to multimeter **Input HI** and **LO** using 600Ω feedthrough termination.
- (2) Press pushbuttons and keys as listed in (a) through (d) below:
 - (a) **DISPLAY** key to select **TRMT**.
 - (b) **NOR** pushbutton.
 - (c) **SET UP TRMT 600 W** pushbutton.
 - (d) **IMPULSE NOISE DISPLAY F2 1004** key.
- (3) Adjust **OUTPUT LEVEL** control for a 2.45 V ac indication on multimeter.
- (4) Press **↵**, **STEP UP**, **STEP DOWN**, and **Ⓜ** keys for TI right display indications listed in table 4. Multimeter indications will be within limits specified.

Table 4. Transmitter Flatness at +10 dBm

Test instrument right display indications	Multimeter indications (Vac)	
	Min	Max
20 Hz	2.183	2.748
10 kHz	2.394	2.507
60 kHz	2.312	2.595
85 kHz	2.312	2.595

- (5) Press **IMPULSE NOISE DISPLAY F2 1004** key.
- (6) Adjust **OUTPUT LEVEL** control for a 0.775 V ac indication on multimeter.
- (7) Press **↵**, **STEP UP**, **STEP DOWN**, and **Ⓜ** keys for TI right display indications listed in table 5. Multimeter indications will be within limits specified.

Table 5. Transmitter Flatness at 0 dBm

Test instrument right display indications	Multimeter indications (Vac)	
	Min	Max
20 Hz	0.690	0.869
10 kHz	0.757	0.793
60 kHz	0.731	0.820
85 kHz	0.731	0.820

- (8) Press **IMPULSE NOISE DISPLAY F2 1004** key.
- (9) Adjust **OUTPUT LEVEL** control for a 7.75 mV ac indication on multimeter.
- (10) Press **↵**, **STEP UP**, **STEP DOWN**, and **Ⓜ** keys for TI right display indications listed in table 6. Multimeter indications will be within limits specified.

Table 6. Transmitter Flatness at -40 dBm

Test instrument right display indications	Multimeter indications (mV ac)	
	Min	Max
20 Hz	6.90	8.69
10 kHz	7.57	7.93
60 kHz	7.31	8.20
85 kHz	7.31	8.20

b. Adjustments. No adjustments can be made.

10. Filters

a. Performance Check

- (1) Connect calibrator **OUTPUT HI** and **LO** to TI left **TRMT/ RCV 310**.
- (2) Press pushbuttons and keys as listed in (a) through (d) below:
 - (a) **DISPLAY** key to select **RCV**.
 - (b) **REV** pushbutton.
 - (c) **SET UP RCV 600 W** pushbutton.
 - (d) **MEASUREMENT MEAS** key to select **NOISE**.
- (3) Set calibrator for a 0 dBm, 300 Hz output.
- (4) Press **FILTER FILTER** key to select **C-MESSAGE**. TI left display will indicate between 73 and 74 dBm.
- (5) Repeat technique of (3) and (4) above at each frequency listed for **C-MESSAGE** column of table 7. TI will indicate within limits specified.
- (6) Repeat technique of (3) and (4) above for TI filter selections using appropriate column and calibrator frequency settings listed in table 7. If TI left display indications are not within limits specified, perform **b** below.

Table 7. Filter Accuracy

Calibrator frequency settings (Hz)	Test instrument FILTER selections and left display indications					
	C-MESSAGE (dBm)	3 kHz FLAT (dBm)	15 kHz FLAT (dBm)	PROGRAM (dBm)	50 KBIT (dBm)	Notch filter ¹ (dBm)
100	---	---	---	62 to 65	---	---
300	73 to 74	---	---	---	---	---
400	---	---	---	---	---	90
500	---	---	---	83 to 84	---	---
862	---	---	---	---	---	≥88
900	89 to 90	---	---	---	---	---
1000	90	90	90	90	90	<40
1020	---	---	---	---	---	<40
1182	---	---	---	---	---	≥88
1700	---	---	---	---	---	90
2000	---	---	---	94 to 95	---	---
2500	88 to 89	---	---	---	---	---
3000	87 to 88	86 to 88	---	---	---	---
4500	66 to 71	---	---	---	---	---
5000	---	---	---	95 to 98	---	---
6000	---	75 to 80	---	---	---	---
10,000	---	---	---	78 to 85	---	---
15,000	---	---	86 to 88	---	89 to 90	---
25,000	---	---	---	---	87 to 88	---
30,000	---	---	75 to 80	---	---	---
35,000	---	---	---	---	84 to 86	---
50,000	---	---	---	---	62 to 67	---

¹Press **MEASUREMENT MEAS** key to select **NOISE WITH TONE** then press **FILTER FILTER** key to select **15 kHz FLAT**.

b. Adjustments

- (1) Press calibrator **RESET** key and disconnect from TI.
- (2) Connect left **TRMT/RCV 310** to right **RCV/TRMT 310**.
- (3) Press **DISPLAY** key to select **TRMT** and **MEASUREMENT MEAS** key to select **LEVEL FREQUENCY**.
- (4) Press **↶**, **STEP UP**, **STEP DOWN**, and **Ⓜ** keys until TI right display indicates 995 Hz. Adjust **OUTPUT LEVEL** control until left display indicates 0.0 dBm.
- (5) Press **DISPLAY** key to select **RCV**.
- (6) Move shorting bars on JU5 (fig. 1) to right (shorting pins 5 to 12, 6 to 11, 7 to 10, and 8 to 9).
- (7) Connect oscilloscope **CH 1** to pin 1 of JU5 (fig. 1).
- (8) Adjust R102 (fig. 1) for minimum ac signal on oscilloscope (R).
- (9) Press **↶**, **STEP UP**, **STEP DOWN**, and **Ⓜ** keys until TI right display indicates 1010 Hz.

- (10) Connect oscilloscope **CH 1** to pin 4 of JU5 (fig. 1).
- (11) Adjust R132 (fig. 1) for minimum ac signal on oscilloscope (R).
- (12) Press \neg , **STEP UP**, **STEP DOWN**, and $\text{\textcircled{R}}$ keys until TI right display indicates 1025 Hz.
- (13) Connect oscilloscope **CH 1** to TP7 (fig. 1).
- (14) Adjust R180 (fig. 1) for minimum ac signal on oscilloscope (R).
- (15) Move shorting bars to original position (JU5 shorting pins 1 to 16, 2 to 15, 3 to 14, and 4 to 13) (fig. 1).

11. Hold Circuit

a. Performance Check

- (1) Connect equipment as shown in figure 2.

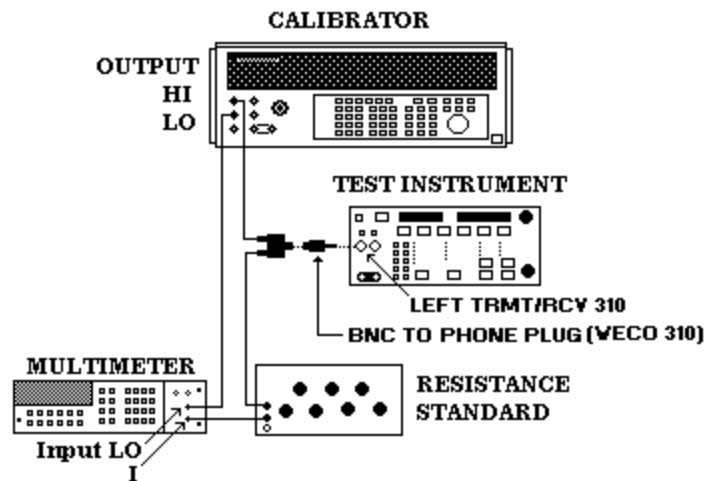

Figure 2. Hold circuit.

- (2) Position controls as listed in (a) through (i) below:
 - (a) Press **DISPLAY** key to select **RCV**.
 - (b) Release **NOR** and **REV** pushbuttons (out).
 - (c) Press **SET UP TRMT 600 W** and **RCV 600 W** pushbuttons.
 - (d) Release **SET UP TRMT DIAL** pushbutton to (out).
 - (e) Press **SET UP RCV BRG** pushbutton (in).
 - (f) Release **SET UP TRMT HOLD** and **RCV HOLD** pushbuttons (out).
 - (g) Press **MEASUREMENT MEAS** key to select **LEVEL FREQUENCY**.

TB 9-6625-2151-35

- (h) Press **IMPULSE NOISE DISPLAY F2 1004** key.
 - (i) Adjust **OUTPUT LEVEL** control for a -40 dBm indication on left display.
- (3) Set multimeter to measure dc current on 100 mA manual range and resistance standard dials for 400Ω.
- (4) Set calibrator for a 16.5 V dc output.
- (5) Press **SET UP TRMT HOLD** pushbutton (in). If multimeter does not indicate between 23.5 and 24.5 mA, perform **b** below.
- (6) Set calibrator for a 50 V dc output. Multimeter will indicate less than 26 mA. Release **SET UP TRMT HOLD** pushbutton (out). TI left display indication will not change.
- (7) Repeat (4) through (6) above for **SET UP RCV HOLD** pushbutton.

b. Adjustments

- (1) Set calibrator for a 6.9 V dc output and resistance standard dials for 0.0Ω.
- (2) Position controls as listed in (a) through (c) below:
 - (a) Press **DISPLAY** key to select **TRMT**.
 - (b) Press **NOR** pushbutton.
 - (c) Press **SET UP TRMT HOLD** and **RCV HOLD** pushbuttons (in).
- (3) Adjust R53 XMT HOLD (fig. 3) until multimeter indicates 24 mA (R).

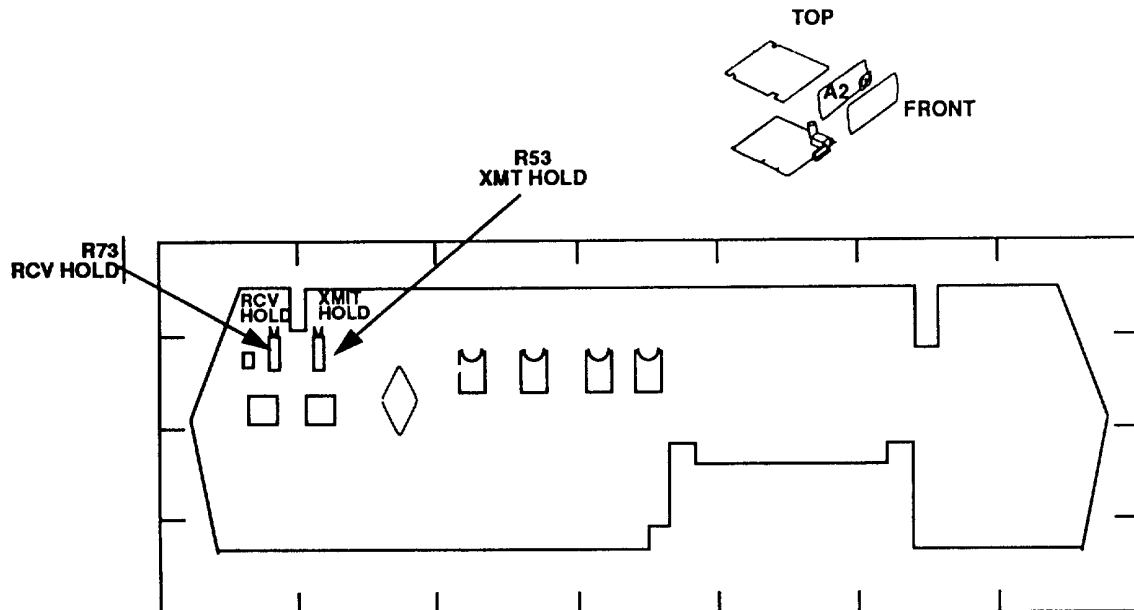

Figure 3. A2 board - adjustment locations.

- (4) Set calibrator for a -6.9 V dc output. Multimeter indication will not change.
- (5) Set calibrator for a 6.9 V dc output.
- (6) Press **REV** pushbutton.
- (7) Adjust R73 RCV HOLD (fig. 3) until multimeter indicates 24 mA (R).
- (8) Repeat (4) above.
- (9) Adjust calibrator for a 50 V dc output. Multimeter will indicate less than 26 mA.
- (10) Press **NOR** pushbutton. Multimeter will indicate less than 26 mA.

12. Distortion

a. Performance Check

- (1) Connect TI left **TRMT/RCV 310** to audio analyzer **INPUT HIGH** using 600 Ω feedthrough termination.
- (2) Position controls as listed in (a) through (f) below:
 - (b) Press **DISPLAY** key to select **TRMT**.
 - (a) Press **NOR** pushbutton.
 - (c) Press **SET UP TRMT 600 W** pushbutton.
 - (d) Press **MEASUREMENT MEAS** key to select **LEVEL FREQUENCY**.
 - (e) Press \leftarrow , **STEP UP**, **STEP DOWN**, and $\text{\textcircled{R}}$ keys until TI right display indicates 85.000 kHz.
 - (f) Adjust **OUTPUT LEVEL** control until left display indicates 0.0 dBm.
- (3) Set audio analyzer to measure frequency. Audio analyzer will indicate between 84.996 and 85.004 kHz.
- (4) Press **IMPULSE NOISE DISPLAY F2 1004** key.
- (5) Set audio analyzer to measure distortion in dB and input to floating. Audio analyzer will indicate ≤ -50 dB.

b. Adjustments. No adjustments can be made.

13. Peak-to-Average Ratio (Options 002 and 003 Only)

a. Performance Check

- (1) Connect calibrator **OUTPUT HI** and **LO** to TI left **TRMT/ RCV 310**.
- (2) Press pushbuttons and keys as listed in (a) through (d) below:
 - (a) **DISPLAY** key to select **RCV**.
 - (b) **REV** pushbutton.
 - (c) **SET UP TRMT 600 W** and **RCV 600 W** pushbuttons.
 - (d) **MEASUREMENT MEAS** key to select **P/AR**.

TB 9-6625-2151-35

(2) Set calibrator for a -3.9 dBm, 300 Hz output. If TI left display does not indicate -30 dBm, perform **b(l)** through (10) below.

(3) Set calibrator frequency to 1000 Hz. If TI left display does not indicate 0 dBm, perform **b(l)** through (10) below.

(4) Set calibrator frequency to 2300 Hz. If TI left display does not indicate -10 dBm, perform **b(l)** through (10) below.

(5) Press **DISPLAY** key to select **TRMT**. If right display does not indicate between 99 and 101, perform **b(11)** below.

(6) Vary **OUTPUT LEVEL** control to obtain a left display indication between -12 and -1 dBm. Right display indication will not change by more than 1 P/AR unit.

b. Adjustments

(1) Press calibrator **RESET** key and disconnect from TI.

(2) Connect left **TRMT/RCV 310** to right **RCV/TRMT 310**.

(3) Press **MEASUREMENT MEAS** key to select **LEVEL FREQUENCY**.

(4) Press **-**, **STEP UP**, **STEP DOWN**, and **Ⓜ** keys until TI right display indicates 1300 Hz. Adjust **OUTPUT LEVEL** control until left display indicates 0.0 dBm.

(5) Connect oscilloscope **CH 1** to TP 15 pin 2 (fig. 1).

(6) Connect oscilloscope **CH 2** to TP 15 pin 7 (fig. 1).

(7) Set oscilloscope controls as necessary to measure phase difference between signals on **CH 1** and **CH 2**.

(8) Adjust R153 PAR PHASE 1 (fig. 1) to obtain a 0 degree phase difference indication on oscilloscope (R).

(9) Connect oscilloscope **CH 1** to TP15 pin 8 (fig. 1).

(10) Adjust R175 PAR PHASE 2 (fig. 1) to obtain a 0 degree phase difference indication on oscilloscope (R).

(11) Adjust R186 PAR DET (fig. 1) until TI right display indicates 100 (R).

14. Power Supply

NOTE

Do not perform power supply check if all other parameters are within tolerance.

a. Performance Check

(1) Connect multimeter **Input HI** to JU+5 (fig. 4) and **LO** to ground. If multimeter does not indicate between 4.8 and 5.2 V dc, perform **b(l)** below.

(2) Connect multimeter **Input HI** to JU+14 (fig. 4). If multimeter does not indicate between 13.8 and 14.2 V dc, perform **b(2)** below.

(3) Connect multimeter **Input LO** to JU-14 (fig. 4) and **HI** to ground. Multimeter will indicate between -13.75 and -14.25 V.

b. Adjustments

- (1) Adjust R42 +5V ADJ (fig. 4) for a +5 V dc indication on multimeter.
- (2) Adjust R31 +14V ADJ (fig. 4) for a +14 V dc indication on multimeter.

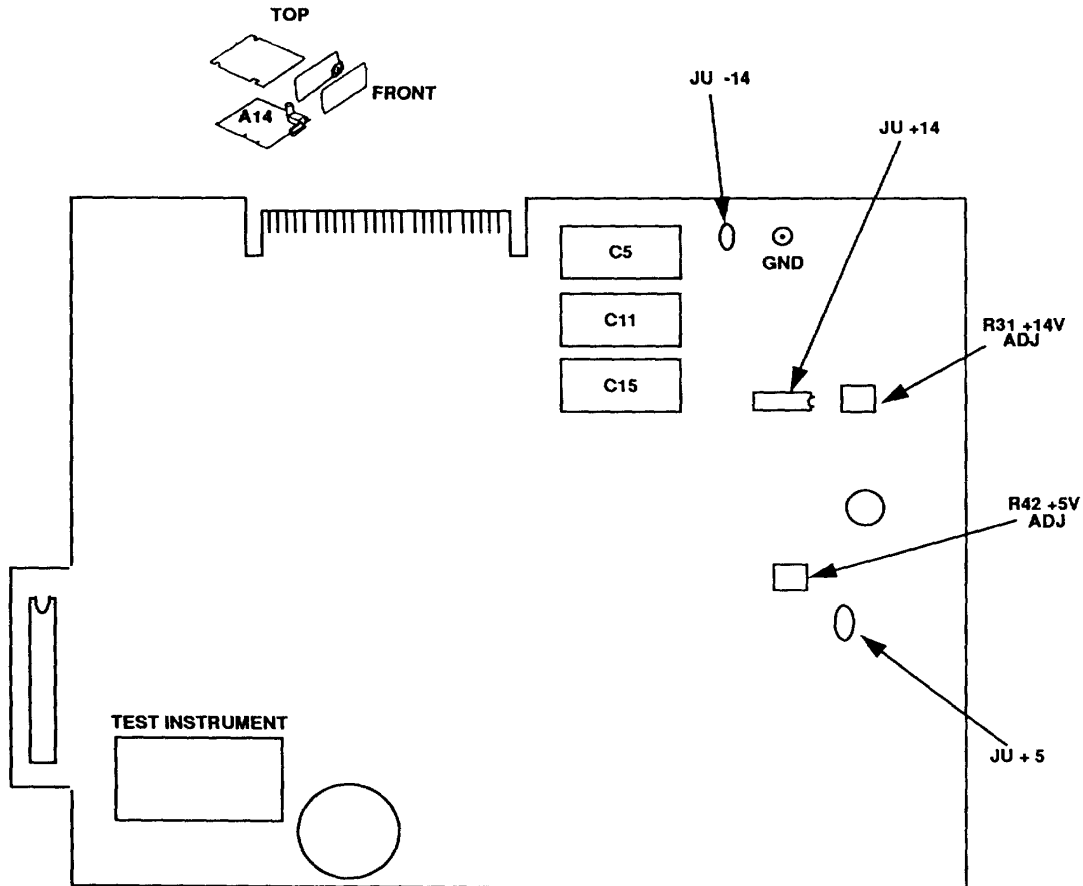

Figure 4. Transmitter A14 board - component locations.

15. Final Procedure

- a. Deenergize and disconnect all equipment.
- b. Annotate and affix DA Label/Form in accordance with TB 750-25.

Instructions for Submitting an Electronic 2028

The following format must be used if submitting an electronic 2028. The subject line must be exactly the same and all fields must be included; however, only the following fields are mandatory: 1, 3, 4, 5, 6, 7, 8, 9, 10, 13, 15, 16, 17, and 27.

From: "Whomever" whomever@redstone.army.mil

To: <2028@redstone.army.mil

Subject: DA Form 2028

1. **From:** Joe Smith
2. Unit: home
3. **Address:** 4300 Park
4. **City:** Hometown
5. **St:** MO
6. **Zip:** 77777
7. **Date Sent:** 19-OCT -93
8. **Pub no:** 55-2840-229-23
9. **Pub Title:** TM
10. **Publication Date:** 04-JUL-85
11. Change Number: 7
12. Submitter Rank: MSG
13. **Submitter FName:** Joe
14. Submitter MName: T
15. **Submitter LName:** Smith
16. **Submitter Phone:** 123-123-1234
17. **Problem:** 1
18. Page: 2
19. Paragraph: 3
20. Line: 4
21. NSN: 5
22. Reference: 6
23. Figure: 7
24. Table: 8
25. Item: 9
26. Total: 123
27. **Text**

This is the text for the problem below line 27.

By Order of the Secretary of the Army:

Official:

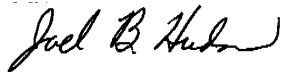

JOEL B. HUDSON

*Administrative Assistant to the
Secretary of the Army*

0313201

JOHN M. KEANE
*General, United States Army
Acting Chief of Staff*

Distribution:

To be distributed in accordance with IDN 342250, requirements for calibration procedure TB 9-6625-2151-35.